

TRAVERSE SELECTION

To select the right unit for your application you need to determine the following:

1. Side Thrust Requirement

The side thrust rating for each model is given overleaf in Table 1.

Your side thrust requirement (F_2), if used in a typical winding application, can be determined using the following formula.

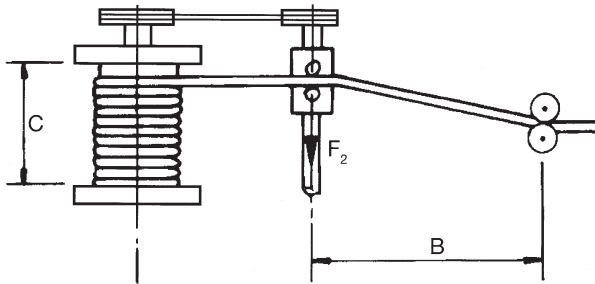

$$F_2 = \frac{(C \times F_1)}{(1.6 \times B)}$$

Where F_1 = line tension in Newtons

Important note on side thrust:

It is important to estimate side thrust to ensure that the critical factors in your application are recognised. Often more side thrust is assumed to be necessary than is actually needed.

The stated side thrust in Table 1 is the value set in our factory for standard unit. If a higher value is required it is possible in most circumstances to increase the power by a simple adjustment.

All current Marldon units have 3 rings inside. Competitor companies often promote 4 ring units on the basis that 4 rings give greater power. This is a fact. However, it should be recognised that often this extra power is redundant and the true reason for the proposal is the greater stability on the shaft afforded by the 4 ring unit in **their** design. Marldon 3 ring units are already stable on the shaft without the need of a 4th ring.

2. Distance to be Traversed

In winding applications this is the inside distance between the flanges of the reel. This distance will be limited for any particular size of traverse unit to the extent that the shaft must not bend under the combined weight of the traverse unit and any other load carried by it.

The adjacent chart shows the acceptable combinations of shaft length and imposed load. If your application exceeds the unit's capability, a secondary support structure should be used where the weight is supported by other means and the traverse unit only provides the reciprocating motion.

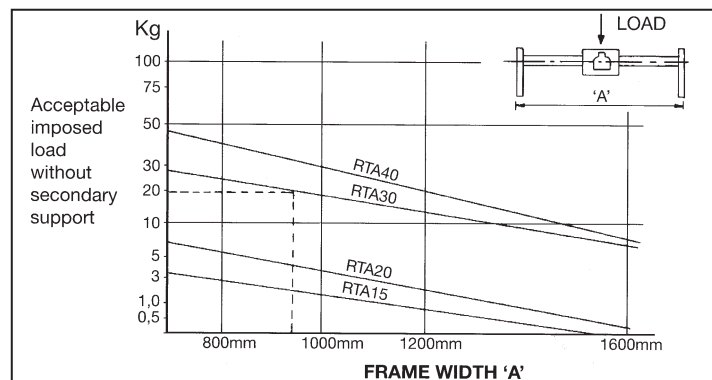

3. Rate of Traverse (pitch)

In most winding applications, for one revolution of the reel, the traverse needs to move a distance of one diameter of the material being wound. As the rate of traverse can be varied by moving the pitch lever, the optimum relationship between pitch setting and shaft speed needs to be selected.

The traverse shaft is driven by the reel shaft using a toothed belt. For best results the traverse shaft speed should be kept at a minimum and the traverse pitch near maximum. The optimum ratio of reel shaft speed to traverse shaft speed can be calculated as:

$$\frac{\text{maximum pitch per revolution of the traverse unit (per table 1)}}{\text{maximum product diameter} \times 1.1}$$